

# RCA

## Power Amplifier

(UNI-RECTRON—MODEL AP-935)

### SERVICE NOTES

*Third Edition—5M—June, 1928*



RCA Uni-Rectron—Model AP-935

## Radio Corporation of America

SERVICE DIVISION OF THE PRODUCTION AND SERVICE DEPARTMENT

233 BROADWAY, NEW YORK CITY

### DISTRICT SERVICE STATIONS

326 Broadway  
New York City

2001 West Pershing Road  
Chicago, Ill.

274 Brannan St.  
San Francisco, Cal.

# RCA POWER AMPLIFIER

(UNI-RECTRON—MODEL AP-935)

## SERVICE NOTES

PREPARED BY RCA SERVICE DIVISION

## INTRODUCTION

RCA Uni-Rectron, Model AP-935, is a power amplifier unit containing suitable rectifying devices for operation from an alternating current house lighting circuit rated at 110-120 volts, 50 to 60 cycles. No attempt should be made to operate it from a direct current circuit or from an alternating current source of voltage or frequency other than specified. Such misuse may result in serious damage to the Uni-Rectron.

There is one Radiotron UX-210 and one Rectron UX-216B employed in the Uni-Rectron. The Rectron UX-216B converts or rectifies the alternating current supply to pulsating direct current which is smoothed out by the filter system and used as plate current by the power amplifier, Radiotron UX-210. The new RCA Radiotron UX-281 is interchangeable with Rectron UX-216B in the RCA Power Amplifier, and has the advantage of increased operating life.

## PROTECTIVE SEALS AND THEIR USE

The lead seals placed on Uni-Rectrons by the RCA are for the protection of the dealer. Broken seals indicate tampering.

A service man may find it necessary to break the seals in order to make repairs. In such instances he should replace those broken by suitable substitute seals when the repair work is finished. Thus he is aided in determining whether any trouble that may develop later is due to tampering or ordinary wear and tear of assembled parts. The unit that has been tampered with will be indicated by a broken seal. This information places the dealer in a preferred position when it is found necessary to render a bill for service.

## SERVICE DATA

Place Rectron UX-216B and Radiotron UX-210 in their respective sockets and see that they are firmly seated. Having ascertained that the lighting circuit is of alternating current of the proper voltage and frequency, insert plug in socket and pull Uni-Rectron switch to "on" position. Both tubes should light.

### (1) IF NEITHER TUBE LIGHTS

Look for:

- (a) Blown fuse in lighting circuit (check voltage of outlet socket used with a test lamp).
- (b) Loose plug in lighting socket.
- (c) Operating switch on Uni-Rectron not making proper contact.
- (d) Open in power supply cord.
- (e) Defective Radiotron or Rectron.
- (f) Open in transformer. (Run continuity test.)

The remedies for the above conditions are obvious, but in the event that trouble still exists check the voltage and frequency of the house lighting current. If these are correct run the complete continuity test shown on pages 7 and 8 to isolate the trouble.

## (2) IF ONE TUBE LIGHTS AND OTHER DOES NOT

Look for:

- (a) Open in filament winding of power transformer.
- (b) Open in connections at filament contacts of socket.
- (c) Defective Rectron or Radiotron.

## (3) EXCESSIVE HUM IN OPERATION

May be due to:

- (a) Defective Rectron UX-216B.
- (b) Ground terminal not connected.
- (c) Ground connections in Uni-Rectron open. (Check diagram and continuity for grounds.)
- (d) Connections in plug to A.C. line reversed. (Try reversing plug.)
- (e) Loose laminations in power transformer or choke. (This is generally accompanied by a physical vibration.)

Any loose items such as clamps, nuts, screws, bolts and transformer laminations may cause a serious hum in operation. These should all be gone over carefully and tightened where necessary, paying particular attention to the nuts, bolts and clamps holding the transformer and choke coils.

## (4) DECREASED LOUDSPEAKER VOLUME

May be caused by:

- (a) Defective loudspeaker. Check speaker on radio receiver known to be operating satisfactorily.

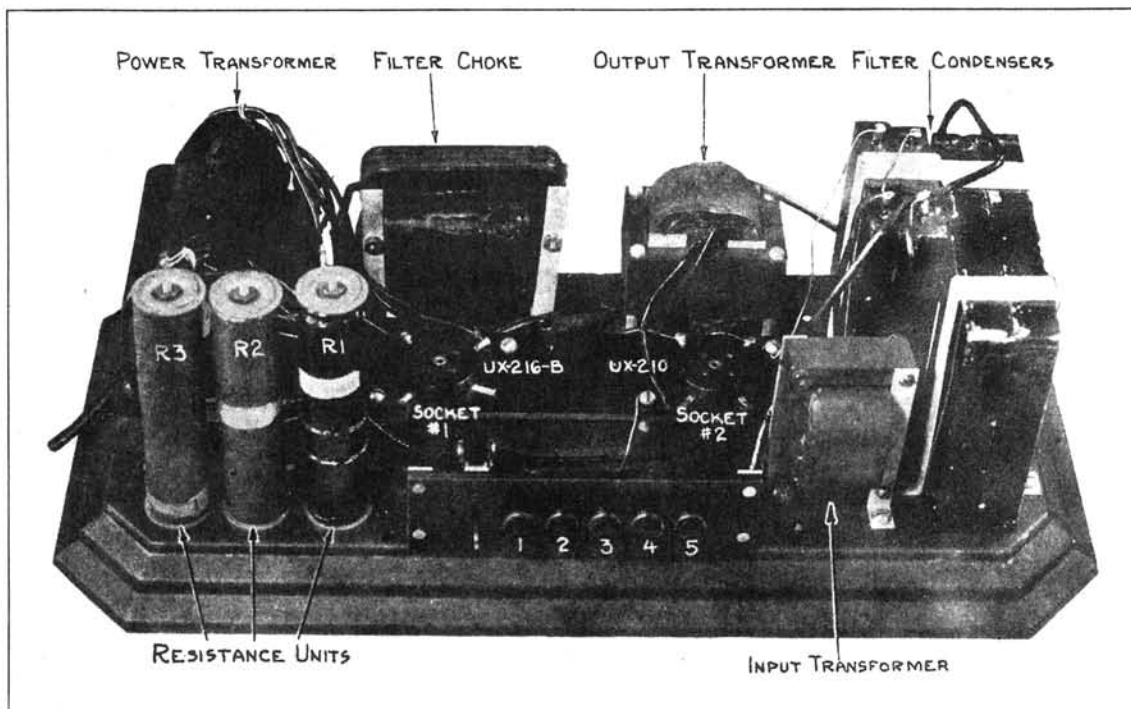

Figure 1

Rear view of Uni-Rectron with cover removed showing location of various parts

- (b) Weak signals from radio receiver. Check output with pair of phones.
- (c) Defective Radiotron UX-210 or Rectron UX-216B. (Defective Rectron UX-216B may cause low plate voltage which in turn would cause decrease of loudspeaker output.)
- (d) Defective input or output transformer. (Check continuity, including grounds to core.)
- (e) Low plate voltage. Measure with high resistance type of voltmeter.
- (f) Defective transformer windings. High voltage secondary having shorted turns.

### (5) MAGNETIC PULL TESTS FOR ISOLATING TROUBLE

These tests are made by holding a steel screw driver in proximity to the iron core of the choke coil and noting the degree of magnetic pull together with the condition of the plate of the Rectron UX-216B. (See Figure 3.)

<i>Magnetic Pull</i>	<i>Color of Plate</i>	<i>Defect</i>
(a) Excessive	Dull red	3½ Mfd. condenser No. 2 shorted.
(b) None	White hot	3½ Mfd. condenser No. 1 shorted.
(c) None	Normal	Defective power transformer or open choke.
(d) Excessive	Normal	Shorted elements in Radiotron UX-210.

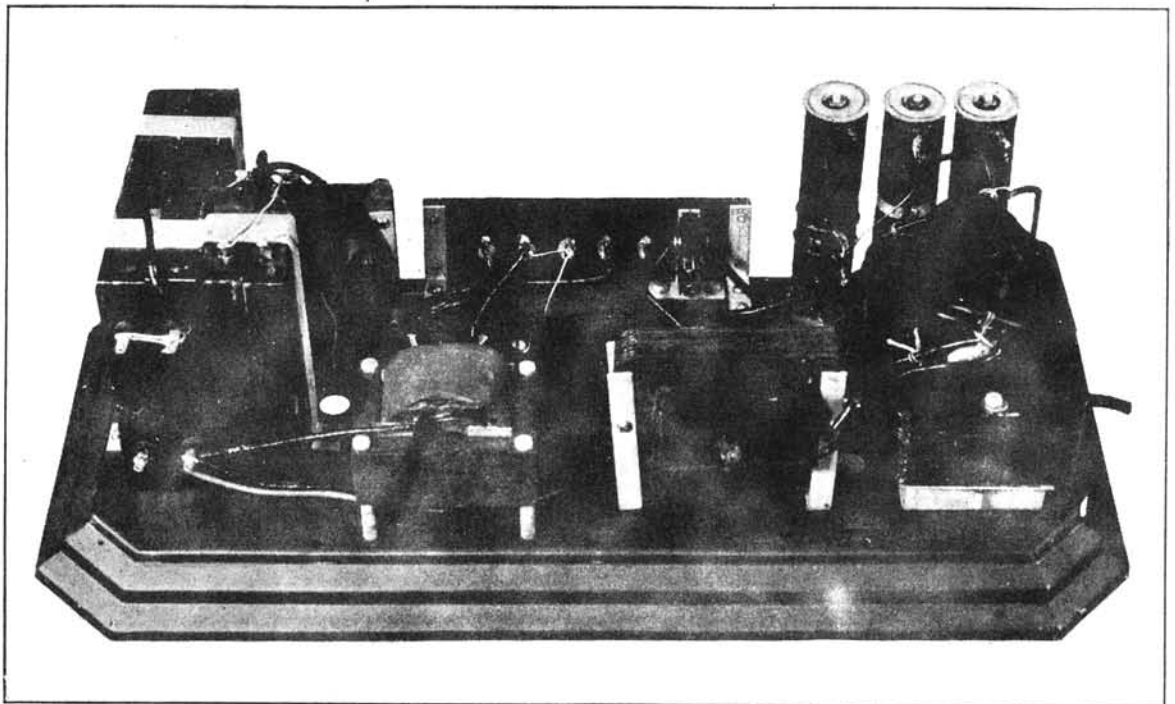
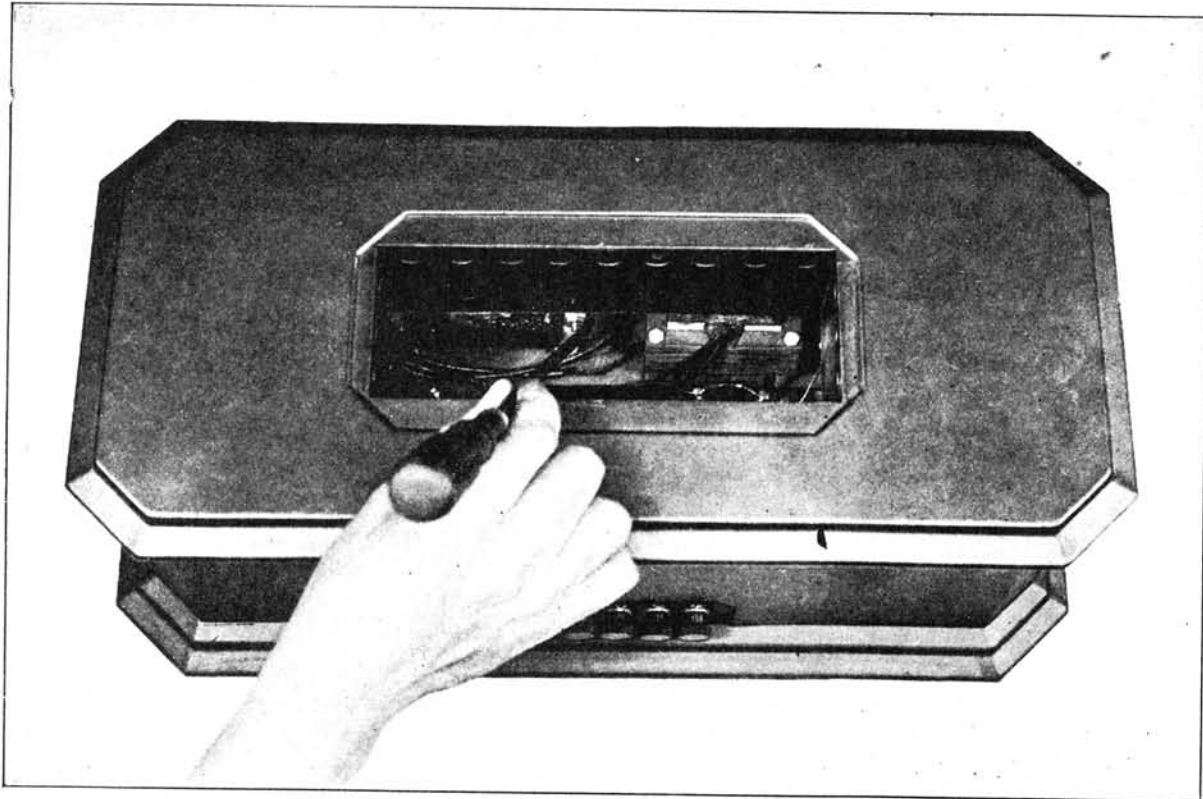

Figure 2  
Uni-Rectron—Front view with cover removed



*Figure 3*  
*Location of screw driver for Magnetic Pull Test*

**(6) IF FILAMENTS OF RECTRON UX-216B AND RADIOTRON UX-210 LIGHT EXCESSIVELY BRIGHT**

Look for:

- (a) Shorted turns in primary of power transformer.
- (b) Alternating current supply of excessive voltage.
- (c) Open plate winding of power transformer.

**(7) PLATE OF RECTRON UX-216B TURNS RED**

Look for:

- (a) Shorted  $3\frac{1}{2}$  Mfd. condenser. This condition would be indicated by an excessive pull on the choke. To further isolate this trouble, run Magnetic Pull Test given in Section 5.
- (b) Short in power transformer secondary windings.
- (c) Shorted Radiotron UX-210. Tube will become hot, but will not necessarily show color.

## (8) COMPLETE CONTINUITY TEST

(Use Phones in series with a 4½ volt "C" battery.)

Terminals	Correct Effect	Incorrect Effect Caused by
1 to 2	Click through primary of input transformer	Open primary input transformer
4 to 5	Click through secondary of output transformer	Open secondary output transformer
4 to 3	Click through connections	Open lead
4 to ground	Click through connections	Open lead

Use Voltmeter with Battery voltage sufficient to give full scale deflection when connected directly across battery terminals.

Terminals	Correct Effect	Incorrect Effect Caused by
P1 to P2	Small scale deflection	Open high voltage winding of transformer. Open resistance unit or primary of output transformer

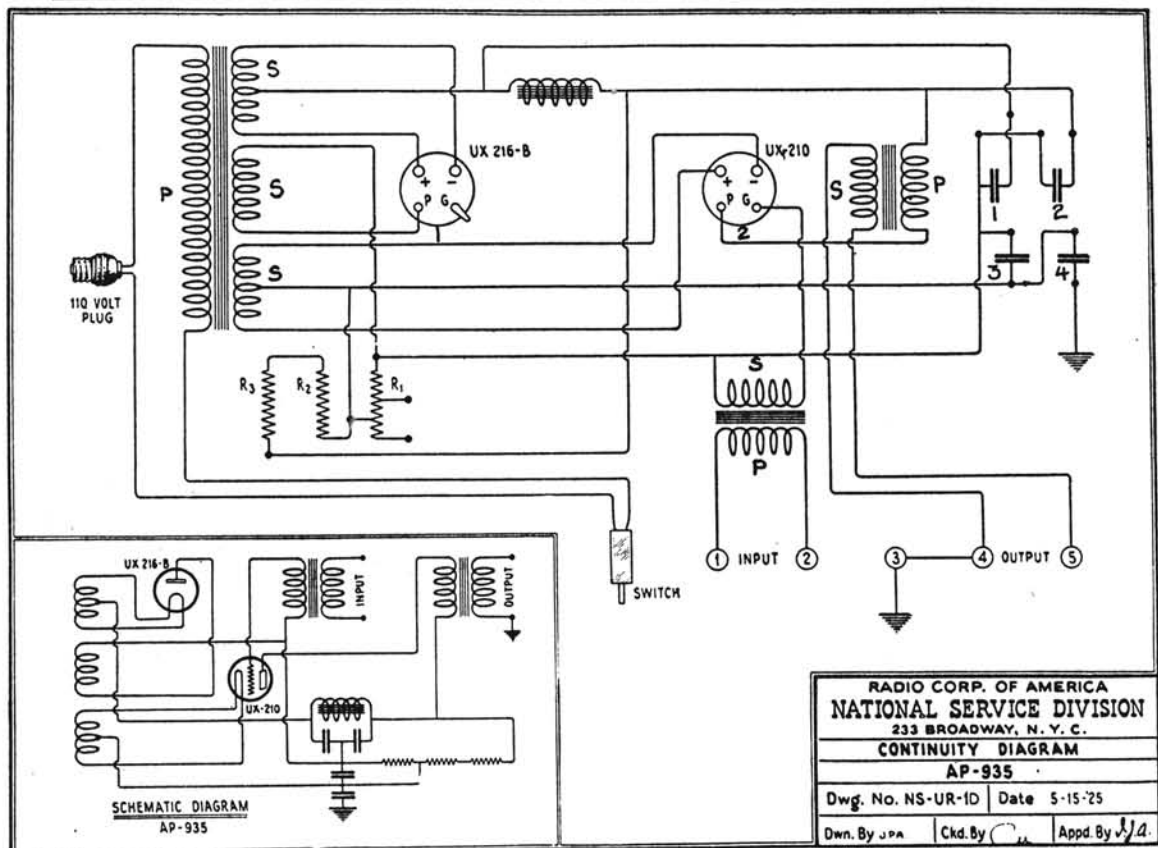

Figure 4  
Continuity diagram RCA Uni-Rectron



<i>Terminals</i>	<i>Correct Effect</i>	<i>Incorrect Effect Caused by</i>
—F1 to +F1	Full scale deflection	Open filament winding of power transformer
P1 to G2	Small deflection	Open (high voltage winding of transformer) (secondary of input transformer)
P2 to —F2 or +F2	Half deflection	Open (primary output transformer) (resistance unit) (filament winding)
P1 to —F1 or +F1	Small deflection	Open (choke) (filament winding) (resistance unit) (plate winding)
Ground to —F2	No deflection	Shorted condenser No. 4

The test points referred to are shown in the Continuity Diagram, Figure 4. The designations "P" and "G" refer to the plate and grid socket contacts. The number immediately following refers to the first or second socket. For example G2 indicates the grid contact of the second socket. P1 indicates the plate contact of the first socket. In the same manner the letter "F" denotes the filament contact of the tube socket indicated by the number.

## (9) RESISTANCE UNIT TESTS

The tests given in Sections 5 and 8 cover every circuit and winding of the Uni-Rectron and will, in practically all cases, isolate trouble to a certain unit or condenser without removing cover or breaking seals. However, it will be necessary to remove the cover in order to replace a defective part. With the cover removed the following tests may also be made:

After the Uni-Rectron has been in operation for some time the normal temperature of the resistance units should be as follows:

- No. 1—Warm.
- No. 2—Warm.
- No. 3—Quite hot.

If No. 1 or No. 2 run excessively hot it is a positive indication of trouble, likewise a lack of heat will indicate an open in the adjacent circuits. The continuity tests should be made to isolate the trouble provided it is not apparent at sight. If trouble has previously been isolated to these resistances they may be clicked for opens at their respective terminal lugs. It will be noted in the case of No. 3 that only a small part of the resistance is in use.

The condensers may also be individually tested for shorts by using the voltmeter and battery. A full scale deflection in any case will be an indication of a shorted condenser. A partial deflection will be an indication of normal operation of condenser No. 1 and No. 2 as these are shunted by resistances. Condenser No. 2 will cause a greater deflection than No. 1. Before testing the condensers discharge any voltage by short circuiting them with a steel screw driver.